



Quality
Endorsed
Company



Product Information Sheet

RazerTrak™ - Belt Trainers

Function

The alignment of trough and return conveyor belt strands.

- > RazerTrak™ Conveyor Belt Trainers are a robust device for the correct alignment of conveyor belt.
- > Provide constant adjustment to the belt under loaded and unloaded conditions.
- > Exert a positive tracking influence without belt damage ensuring central loading is achieved.



Advantages

Load spillage and central alignment of the conveyor belt at load points is a constant concern to system operators. Lost productivity and introduced safety hazards are the result of poorly aligned belts. The RazerTrak™ Belt Tracking System provides these advantages.

- > All RazerTrak Conveyor Belt Trainers are manufactured 100% from Stainless Steel for long and trouble free life.
- > By both pivoting and tilting, the RazerTrak™ ensures full contact to the belt by all rollers at all times.
- > All RazerTrak™ Trainers feature the RazerTrak™ Swivel in 316 stainless steel and covered by 2 years warranty providing dual protection from contaminants while being fully serviceable.
- > Servo Rollers are fully adjustable and machined from Stainless Steel ensuring long life.
- > Purpose built to accept Customers rollers. No extra inventory stock requirements.
- > All models are designed for the specific application.
- > Extra heavy duty construction.

Applications

- > All belt conveyors where tracking of the belt is an important consideration.



Newcastle

Ph (02) 4967 6077
Fax (02) 4960 1784

Muswellbrook

Ph (02) 6541 5088
Fax (02) 6541 5099

Mudgee

Ph (02) 6372 2865
Fax (02) 6372 2646

Parkes

Ph (02) 6863 4808
Fax (02) 6863 4809

Orange

Ph (02) 6361 1443
Fax (02) 6361 1229

Gladstone

Ph (07) 4972 5566
Fax (07) 4972 6566



Quality
Endorsed
Company



Product Information Sheet

TunnelTrak™ Conveyor Belt Trainer

Function

For the correct tracking and alignment of conveyor belt on short centered or reversing conveyors.

- > Captures the return strand of the conveyor belt in a "Tunnel" created by the trainer and the existing conveyor return rollers.
- > Ensures the correct alignment of conveyor belt over head and tail pulleys and under load points.

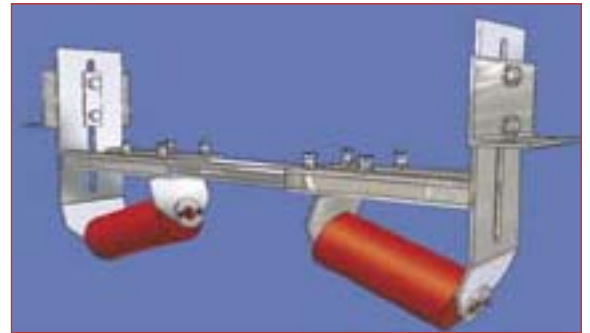

Advantages

By ensuring the correct alignment of the conveyor belt on short centered and reversing conveyors, problems of belt edge damage and material spillage at load points is reduced or eliminated. The Razer TunnelTrak™ Belt Trainer also helps to maintain a clean and safe working environment thus reducing the total cost of conveyor systems ownership.

- > Razer Industries is a 100% Australian owned and operated company.
- > Ideal for short centred conveyors where reaction times of conventional trackers is insufficient.
- > Razer TunnelTrak™ Belt Trainers are manufactured from stainless Steel. All bolts and nuts are also 100% Stainless Steel.
- > Razer TunnelTrak™ are designed to multi-fit to a broad range of conveyor widths. Three basic sizes cover all widths from 450mm to 1800mm conveyor belts.
- > Is easily relocated to any point on the conveyor or to other conveyors within the unit size range.
- > Is fitted and adjusted to the conveyor in minutes.

Applications

- > Best for process and batching plant conveyors where short centred and or reversing conveyors are used.



Newcastle

Ph (02) 4967 6077
Fax (02) 4960 1784

Muswellbrook

Ph (02) 6541 5088
Fax (02) 6541 5099

Mudgee

Ph (02) 6372 2865
Fax (02) 6372 2646

Parkes

Ph (02) 6863 4808
Fax (02) 6863 4809

Orange

Ph (02) 6361 1443
Fax (02) 6361 1229

Gladstone

Ph (07) 4972 5566
Fax (07) 4972 6566



Quality
Endorsed
Company



Manufactured by
Razer Industries

Newcastle

Ph (02) 4967 6077
Fax (02) 4960 1784

Muswellbrook

Ph (02) 6541 5088
Fax (02) 6541 5099

Mudgee

Ph (02) 6372 2865
Fax (02) 6372 2646

Parkes

Ph (02) 6863 4808
Fax (02) 6863 4809

Orange

Ph (02) 6361 1443
Fax (02) 6361 1229

Gladstone

Ph (07) 4972 5566
Fax (07) 4972 6566

TunnelTrak™ Inverted Belt Trainers

Belt Width Range (mm)		Part Number
Minimum	Maximum	
450	650	RTT-0450-0650-S
750	1200	RTT-0750-1200-S
1350	1800	RTT-1350-1800-S

RazerTrak™ Trough & Return Belt Trainers

Belt Width (mm)	Description	Part No.
650	1 ROLL FLAT RETURN	RT650FR
	3 ROLL TROUGH	RT650TR353
750	1 ROLL FLAT RETURN	RT750FR
	3 ROLL TROUGH	RT750TR353
900	1 ROLL FLAT RETURN	RT900FR
	2 ROLL VEE RETURN	RT900VR
	3 ROLL TROUGH	RT900TR353
1000	1 ROLL FLAT RETURN	RT1000FR
	2 ROLL VEE RETURN	RT1000VR
	3 ROLL TROUGH	RT1000TR353
1050	1 ROLL FLAT RETURN	RT1050FR
	2 ROLL VEE RETURN	RT1050VR
	3 ROLL TROUGH	RT1050TR353
1200	1 ROLL FLAT RETURN	RT1200FR
	2 ROLL VEE RETURN	RT1200VR
	3 ROLL TROUGH	RT1200TR353
1400	1 ROLL FLAT RETURN	RT1400FR
	2 ROLL VEE RETURN	RT1400VR
	3 ROLL TROUGH	RT1400TR353
1500	1 ROLL FLAT RETURN	RT1500FR
	2 ROLL VEE RETURN	RT1500VR
	3 ROLL TROUGH	RT1500TR353
1600	1 ROLL FLAT RETURN	RT1600FR
	2 ROLL VEE RETURN	RT1600VR
	3 ROLL TROUGH	RT1600TR353
1800	1 ROLL FLAT RETURN	RT1800FR
	2 ROLL VEE RETURN	RT1800VR
	3 ROLL TROUGH	RT1800TR353

RazerTrak™ - Spare Parts

Part No.	Description	Wt/Kg
RT-Roller	RazerTrak Servo Roller	3.00
RT-BSR-S	RazerTrak Servo Roller Mounting Bracket	0.89
RT-SWVL-STD	Centre Pivot Bearing	5.87

Please note:

- > All prices exclude GST.
- > All prices are FOT Warners Bay NSW, Australia.
- > Alternative finishes, intermediate sizes, larger sizes, purpose built and hydraulically actuated PLC controlled units are available on request.
- > All RazerTrak and TunnelTrak Belt Trainers are manufactured from Stainless Steel.
- > All RazerTrak Trainers are manufactured to accept customer supplied rollers. Prices quoted exclude belt carry rollers (Trough and/or Return).
- > TunnelTrak Trainers are inclusive of rollers.





Quality
Endorsed
Company



Product Information Sheet

Razer SG Return Belt Trainers

Function

The alignment of return conveyor belt strand.

- > Razer SG Conveyor Belt Trainers are a robust device for the correct alignment of conveyor belt.
- > Provide constant adjustment to the belt under loaded and unloaded conditions.
- > Exert a positive tracking influence without belt damage ensuring central loading is achieved.

Advantages

Load spillage and central alignment of the conveyor belt at load points is a constant concern to system operators. Lost productivity and introduced safety hazards are the result of poorly aligned belts. The Razer SG Belt Tracking System provides these advantages.

- > Tracking action is on two plains (XY).
- > Unit not dependant on lagging profile to initiate tracking action.
- > Unit does not required guide rollers to initiate tracking action.
- > All bearings run in an oil bath.
- > The product itself has a 2 year warranty under standard running conditions, excluding the wearing parts such as rubber lagging etc.
- > Average life is 3 to 6 years before reconditioning.
- > Inner unit is sealed against dust by using sealed with O Rings, Double Lip Oil Seals, Felt Seals and Rubber Bellow.
- > Cost effective, only serviceable roller on the market due to the fact that it is built on a module system and can be assembled and disassembled without breaking any high value parts.
- > Refurbished roller will be 45% of the cost of a new roller.

Applications

- > All belt conveyors where tracking of the belt is an important consideration.



Newcastle

Ph (02) 4967 6077
Fax (02) 4960 1784

Muswellbrook

Ph (02) 6541 5088
Fax (02) 6541 5099

Mudgee

Ph (02) 6372 2865
Fax (02) 6372 2646

Parkes

Ph (02) 6863 4808
Fax (02) 6863 4809

Orange

Ph (02) 6361 1443
Fax (02) 6361 1229

Gladstone

Ph (07) 4972 5566
Fax (07) 4972 6566



Quality
Endorsed
Company



Manufactured by
Razer Industries

Newcastle

Ph (02) 4967 6077
Fax (02) 4960 1784

Muswellbrook

Ph (02) 6541 5088
Fax (02) 6541 5099

Mudgee

Ph (02) 6372 2865
Fax (02) 6372 2646

Parkes

Ph (02) 6863 4808
Fax (02) 6863 4809

Orange

Ph (02) 6361 1443
Fax (02) 6361 1229

Gladstone

Ph (07) 4972 5566
Fax (07) 4972 6566

SureGuide Return Belt Trainers

Belt Width (mm)	Description	Part No.	Weight Kg
450	1 ROLL FLAT RETURN	SG45/30	32.30
600	1 ROLL FLAT RETURN	SG60/30	35.43
750	1 ROLL FLAT RETURN	SG75/30	39.83
900 - 1000	1 ROLL FLAT RETURN	SG90/30	44.67
1050	1 ROLL FLAT RETURN	SG105/30	49.28
1200	1 ROLL FLAT RETURN	SG120/30	56.03
1350 - 1400	1 ROLL FLAT RETURN	SG135/40	89.13
1500 - 1600	1 ROLL FLAT RETURN	SG150/40	97.70
1800	1 ROLL FLAT RETURN	SG180/40	110.07

Please note:

- > Prices exclude GST.
- > Prices are FOT Warners Bay NSW Australia.
- > Heavy Duty units are available for 450 - 1200mm belt widths by request.

